

3D MACHINE VISION APPLICATIONS GUIDE

Advanced 3D technology for high-precision measurements and inspections

COGNEX

THE RIGHT CHOICE FOR 3D INSPECTIONS

Whether performing a single profile measurement or scanning an entire surface in 3D, Cognex has the most powerful and robust 3D machine vision solutions. Manufacturers in all industries trust Cognex technology to deliver high accuracy surface feature measurements that go beyond the capabilities of 2D machine vision technology.

- Automotive**3
- Electronics**8
- Food and Beverage**10
- Consumer Products**12
- Logistics**14

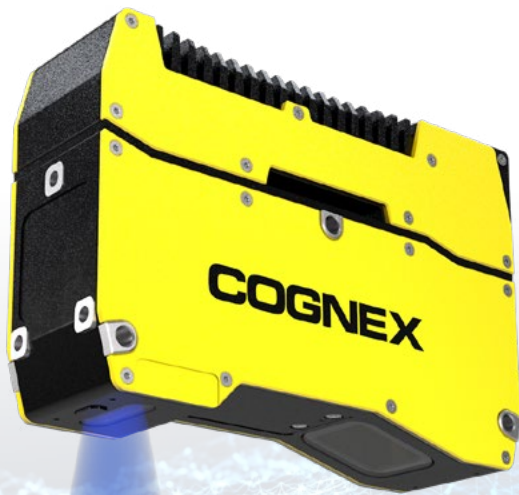
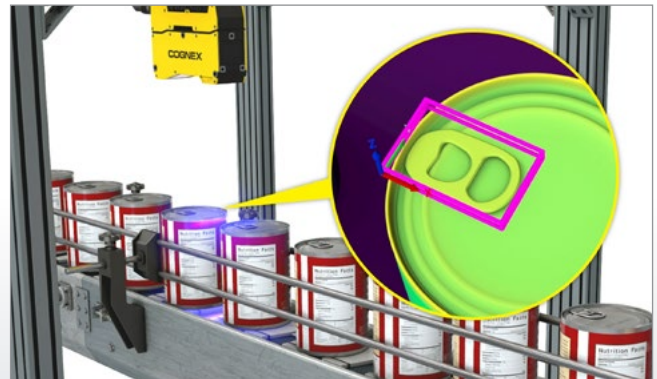
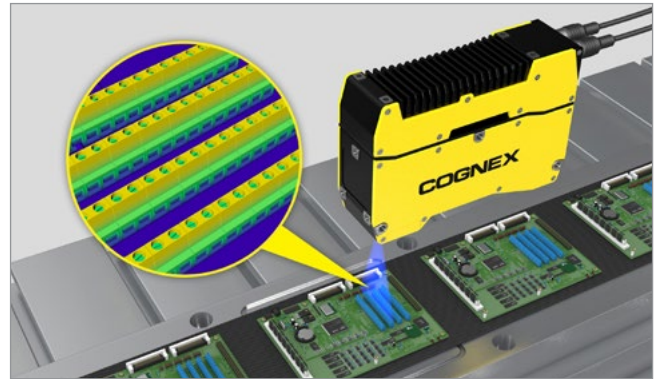
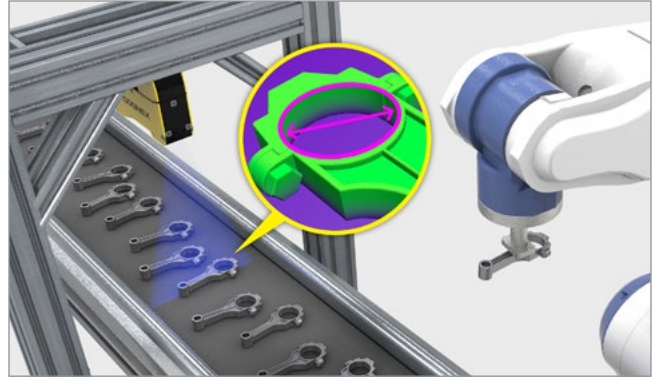

AUTOMOTIVE

3D Machine Vision Solutions that Go the Distance

From assembly to final inspection, nearly every system and component within a gas-powered, hybrid, or electric vehicle is manufactured with machine vision technology. Cognex 3D machine vision systems enable automotive part manufacturers and vehicle assembly plants to achieve exceptional quality and safety, and meet their production goals.

Brake Pad Inspection

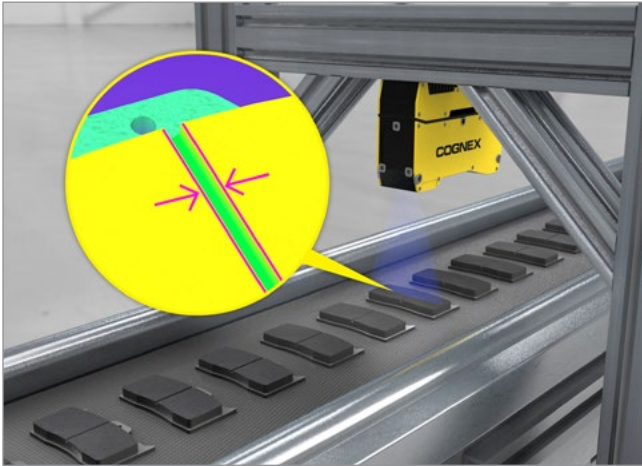

Inspect the gap width for the brake pad and also inspect the angle of the beveled edges.

Connecting Rod Inspection and Location

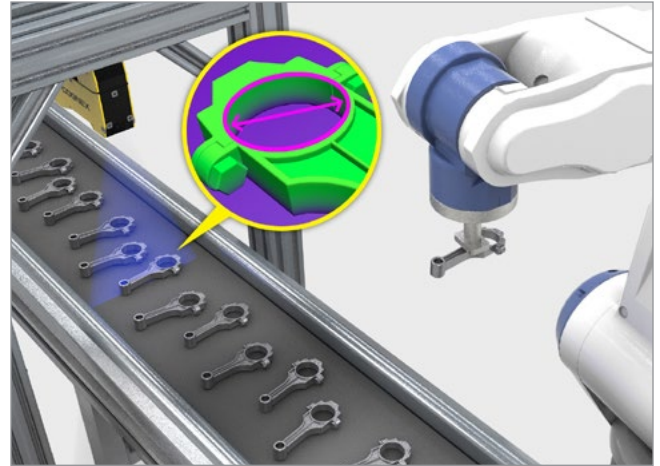

Locate the connecting rod on the belt using PatMax3D and measure the dimensions to ensure there are no part defects.

Electric Vehicle Battery Inspection

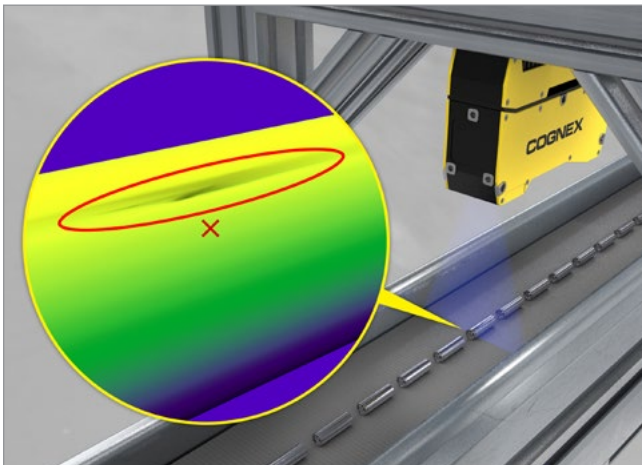

Detect dents, scratches, and other potential defects on the surface of an electric vehicle (EV) battery.

Flush and Gap Inspection

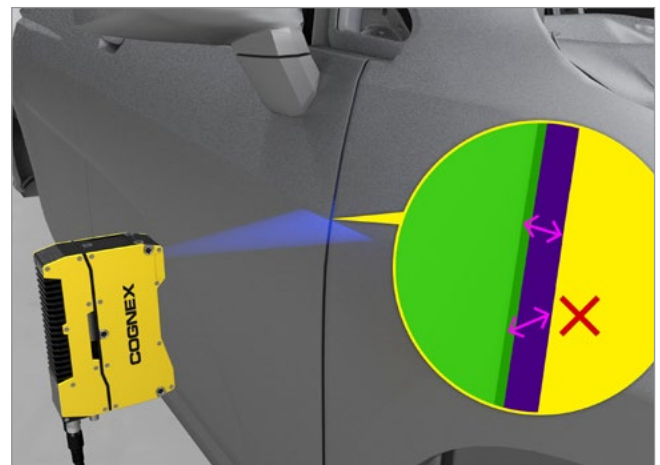

Detect the proper alignment between the door and car body, while ensuring the gap between the two is consistent.

Extruded Rubber Splice Detection

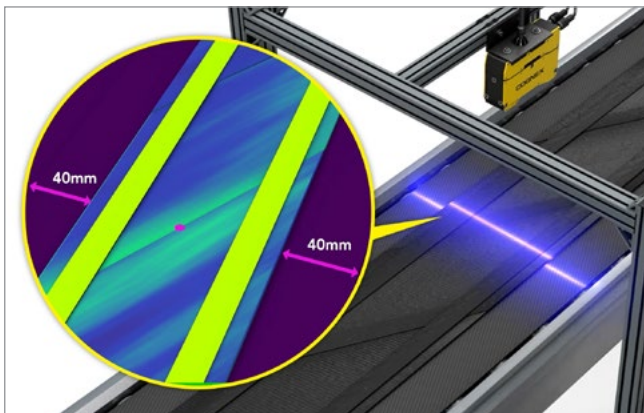

Locate the edge and verify straightness of spliced rubber for tires.

Automotive Casting Inspection

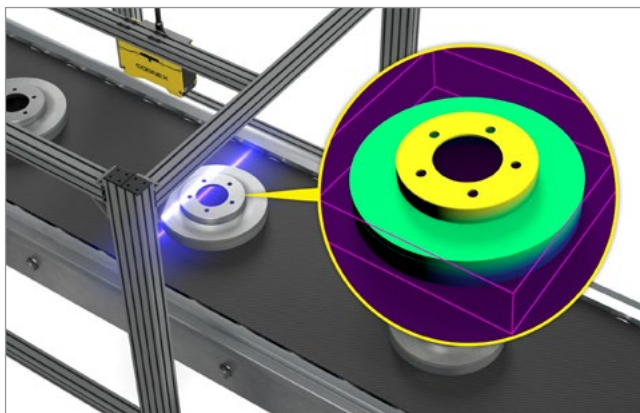

Inspect automotive part volumes for flashing, short shots, and other defects.

Oil Seal and O-Ring Assembly Inspection

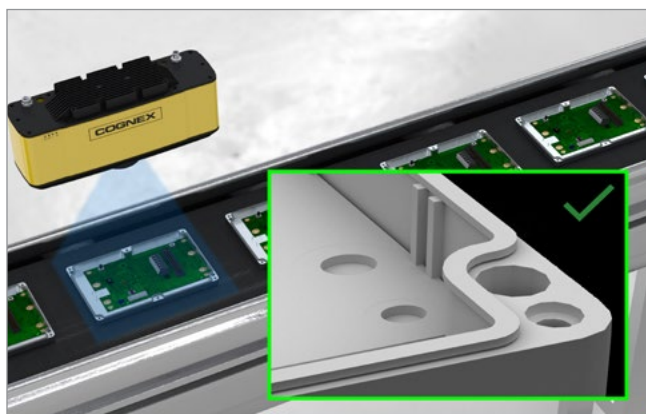

Perform in-line inspection of oil seals and o-rings, and confirm they are set in the correct position to prevent water and oil leakage.

Welding and Brazing

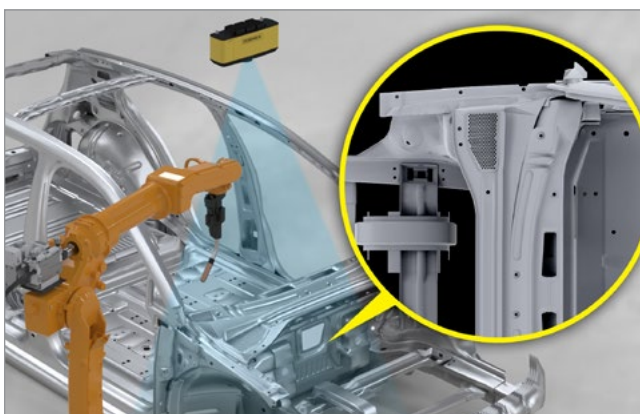

Guide welding robots to the correct location in order to weld the chassis together.

Weld Seam Inspection

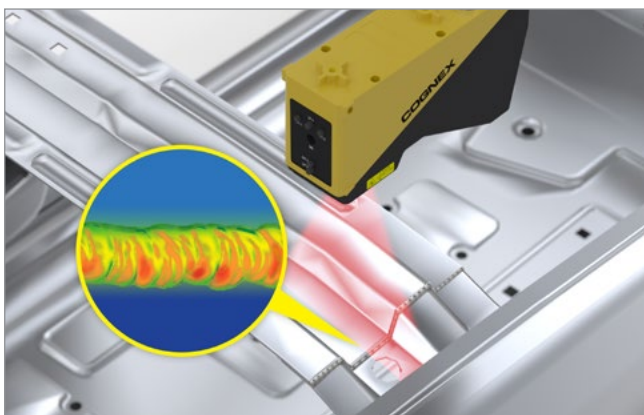

Inspect weld seams to ensure they are complete and the proper thickness.

Racking and Deracking Identification

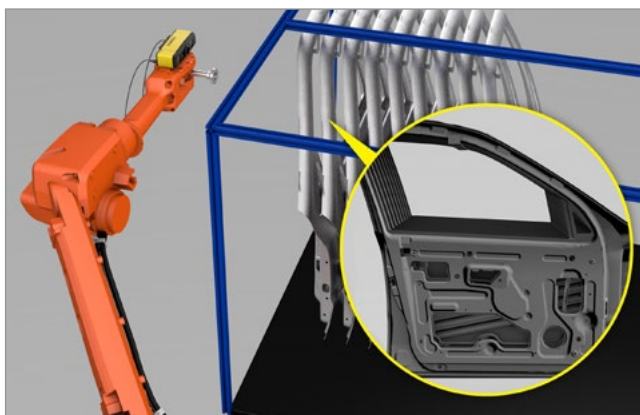

Guide robots to move stamped parts from the line to a rack for inspection and identification.

Engine Component Matching

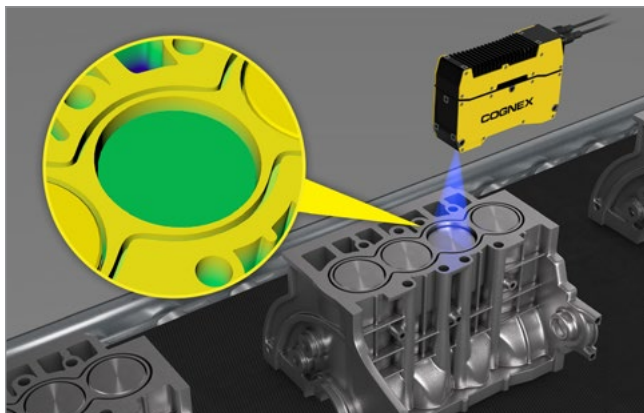

Gauge whether pistons are seated properly in a cylinder block.

Cam Shaft Inspection

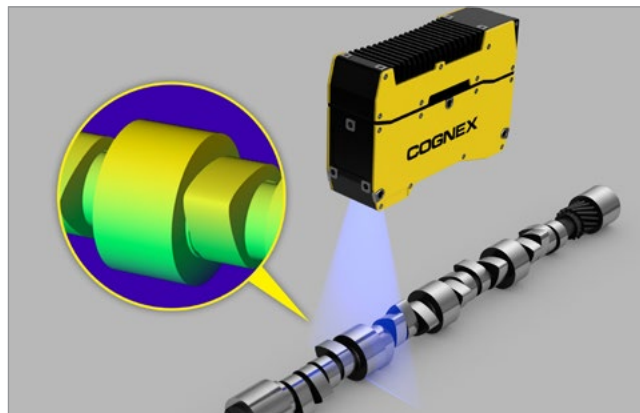

Verify the dimensions of cast parts are manufactured within tolerance.

Airbag Compartment Cover Gap Measurement



Ensure proper alignment of airbag compartment cover and flushness with the dashboard.

Bearing Inspection

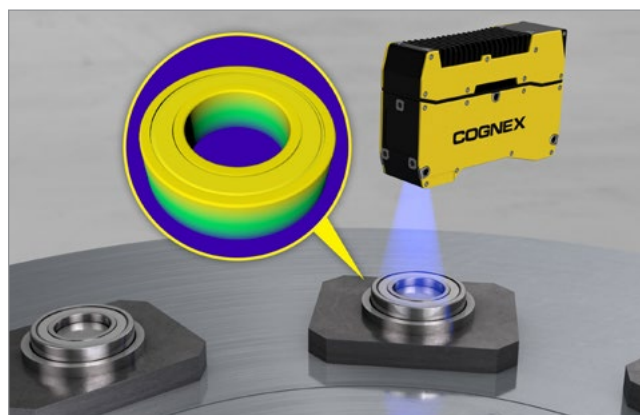

Inspect metal surface for burring and other defects.

Car Seat Wrinkle Detection

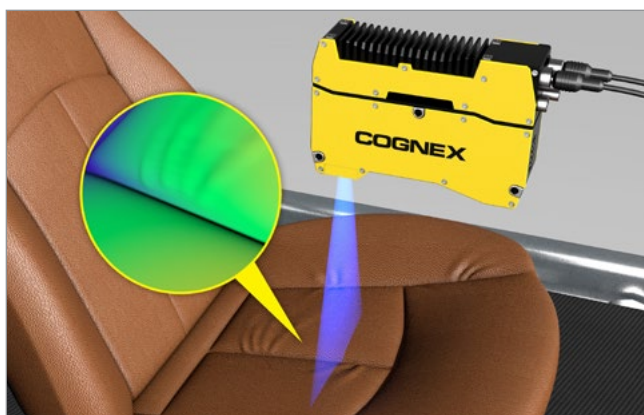

Verify flatness of car seat material and ensure surface is free of wrinkles and unintended creases.

End Face Profile Measurement

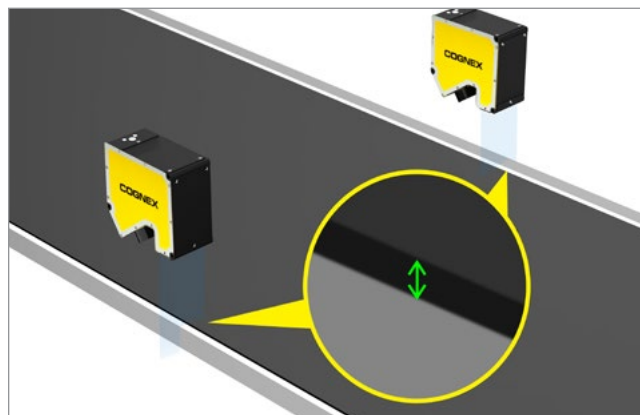

Continuously measure black electrode coatings, even when wet, to detect any waviness in real time.

Cap Welding Guidance and Inspection



Measure the height difference between the cap and battery case prior to welding. Afterwards, inspect the welded seams to ensure they are fully sealed and free of defects.

Battery Pack, Module, and Busbar Welding Inspection

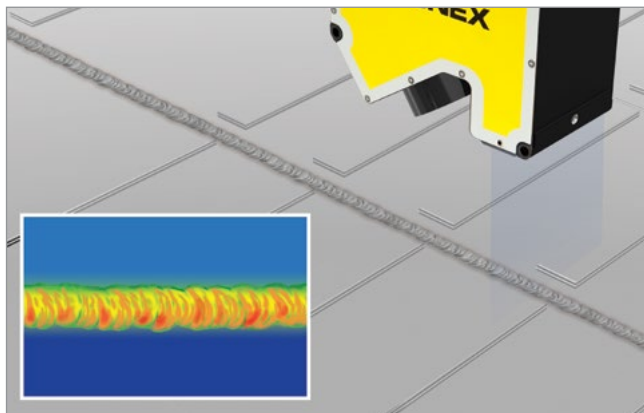

Perform surface measurement of the welds on battery packs and inspect the welds on a battery pack's modules and busbars.

Cell Stacking Height Measurement

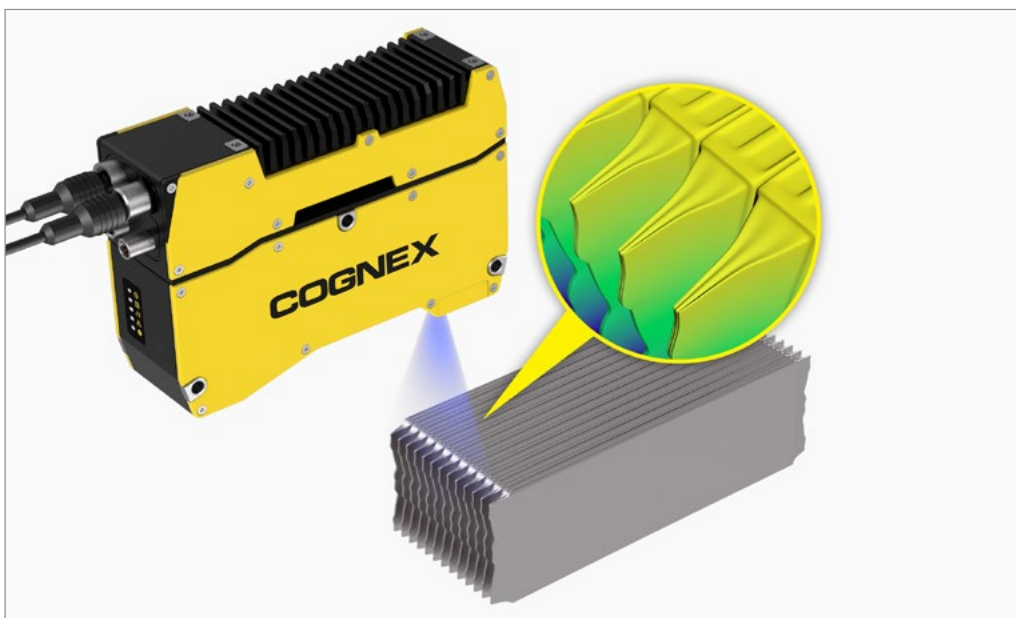

Measure the height of cells stacked inside a battery module to verify uniformity.

Electric Vehicle Battery Module Inspection

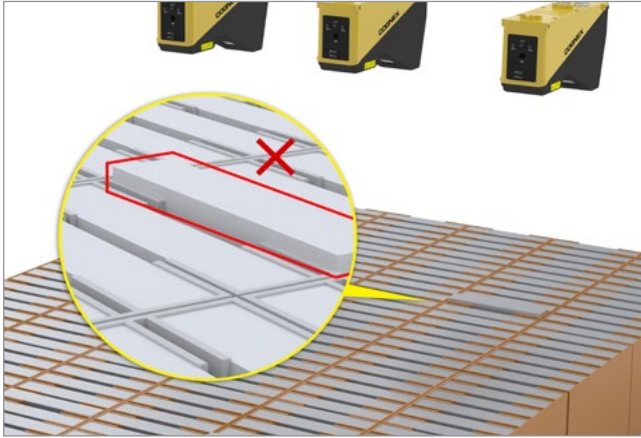

Inspect the seating of EV battery modules.

Terminal Height Measurement

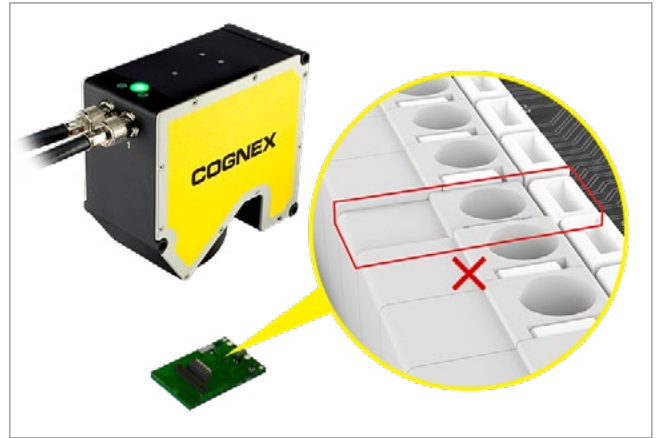

Measure the height profiles of connectors to make sure they are coplanar.

Rotor/Stator Inspection

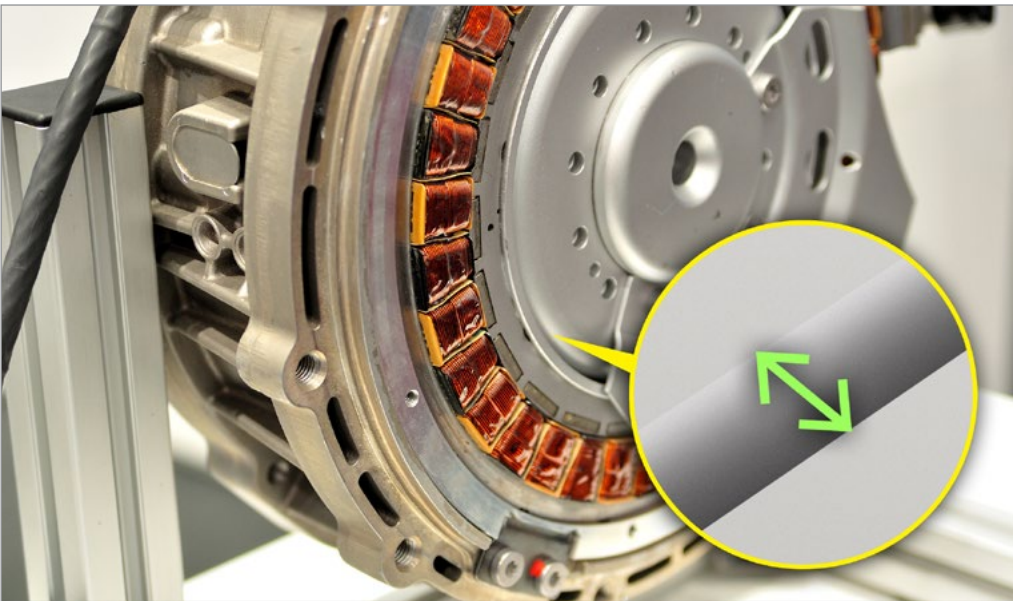

Perform in-line inspection of the narrow gap between rotor and stator, and assess wedge tightness for the magnetic field.

ELECTRONICS

Guide, Inspect, Align, and Identify with 3D Machine Vision

Electronics manufacturers and suppliers rely on Cognex's machine vision solutions to solve their most difficult production and packaging challenges while meeting stringent safety and quality requirements. Cognex laser profilers and 3D vision systems satisfy the toughest applications for electronic materials, semiconductors, components, integrated circuit (IC) packaging, and finished electronic equipment. Driven by powerful vision technology and robust hardware, Cognex tools eliminate defects, verify assembly, and track and capture information during the production lifecycle to achieve maximum quality, high yields, and traceability.

Connector Pin Height Inspection

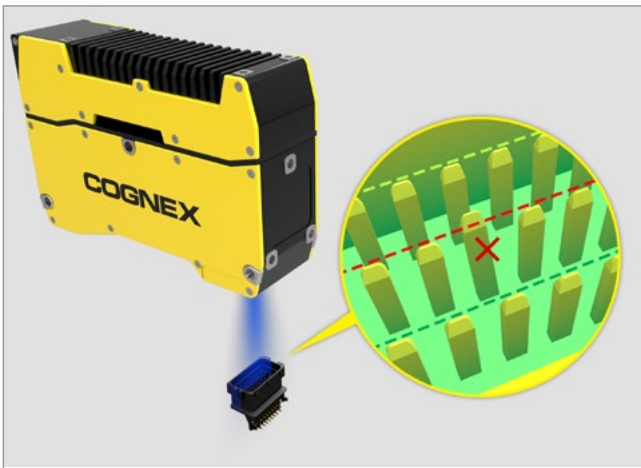

Verify the correct number of pins on the connector and ensure the pins are in the correct position while being free from damage or tilted.

Carrier Flatness Inspection

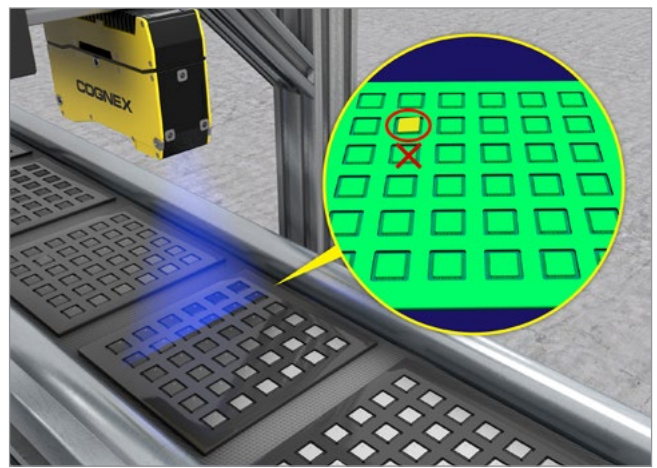

Determine if chips are correctly seated inside the carrier tray by measuring position and flatness.

PCB Inspection

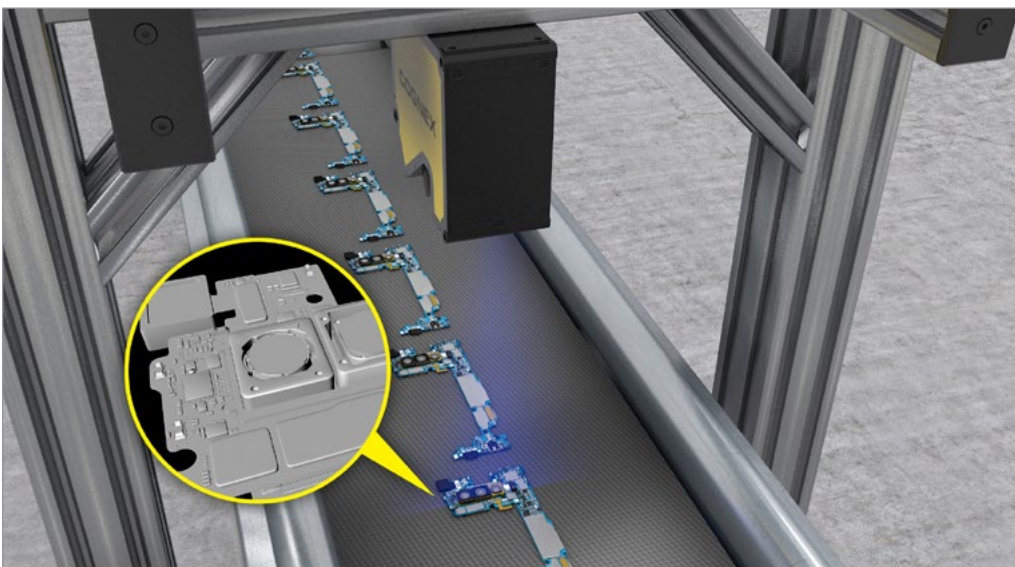

Inspect PCBs for the proper number, size, and placement of components.

Pre-Assembly Insertion Check

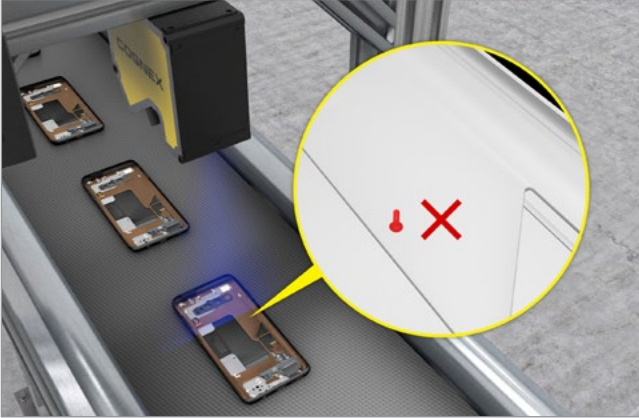

Ensure the module mounting area is free of potential obstructions.

Post-Assembly Verification

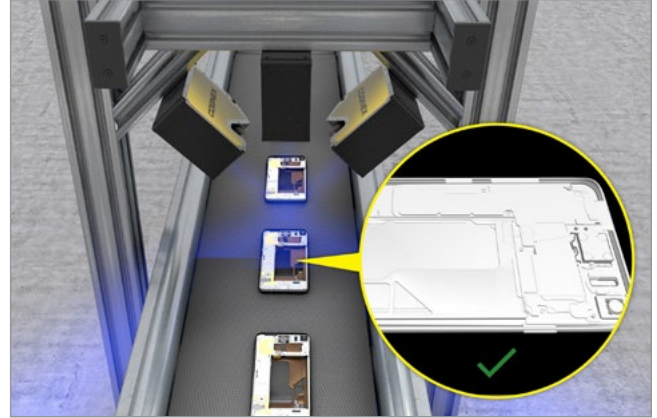

Verify that components are properly installed and meet quality parameters.

Smartphone Camera Height Measurement

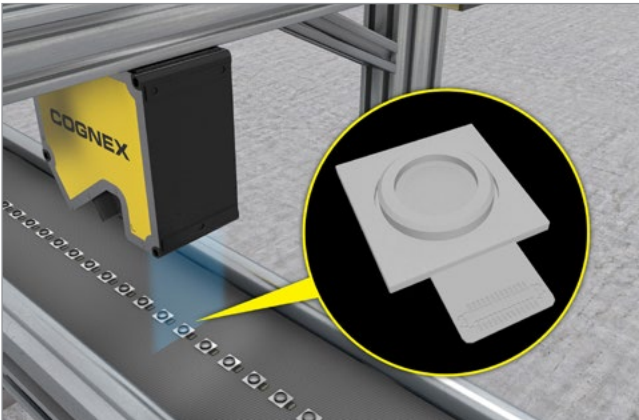

Gauge the height dimensions for a complex, transparent camera assembly.

Smartphone Housing Flatness Inspection

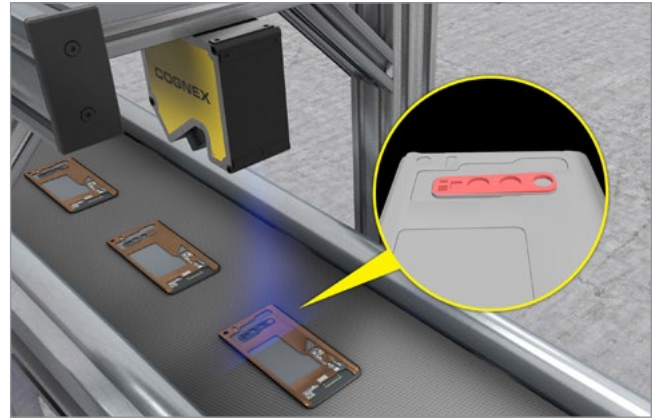

Measure the height of housing and detect the smallest dents to micron-level accuracy.

Screw Assembly Height Measurement

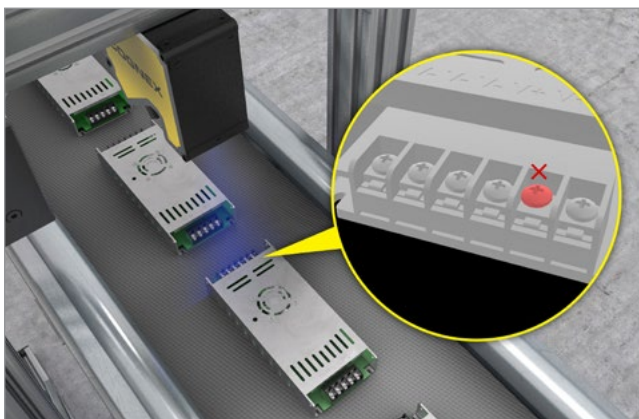

Determine whether the height of the screw is within the accepted range.

Terminal Height Measurement

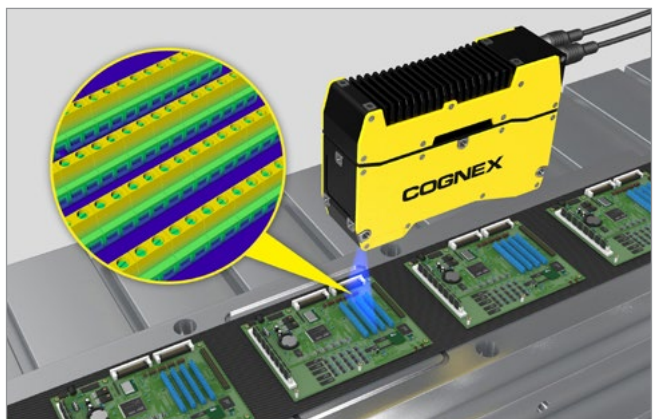

Confirm height of terminals in PCBs.

FOOD AND BEVERAGE

Protect Your Customers and Your Brand with 3D Machine Vision

With lean operations and thin margins, the pressure on the food and beverage industry to optimize overall equipment efficiency without compromising quality is challenging. Successful manufacturers embrace machine vision solutions to minimize downtime and consistently deliver safe, high-quality products. With a wide selection of 3D machine vision systems, Cognex solutions help food and beverage manufacturers solve some of the most challenging inspection and verification applications.

Package Inspection



Determine the presence or absence of items in the packaging and verify the volume of the package.

Item Location

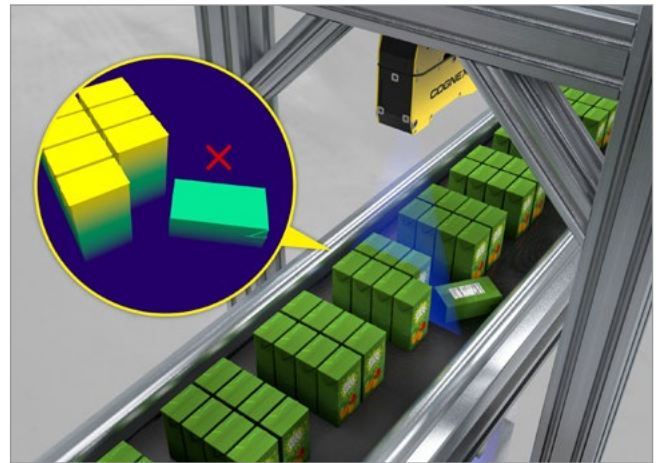

Inspect packages to determine correct number and proper orientation. Also, check for defects in the packaging such as dents or tears.

Cap Inspection



Ensure the bottle is properly sealed by checking the height and tilt angle of the bottle cap.

Cookie Defect Detection

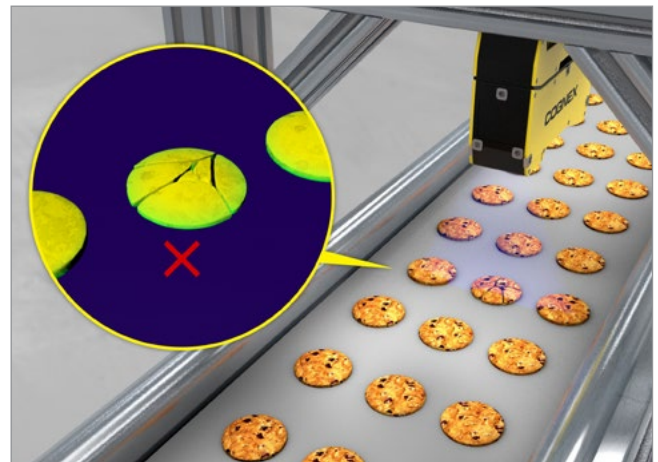

Verify the uniformity of cookies by measuring the length, width, and height. Inspect for defects such as breaks or cracks.

Aluminum Can Inspection

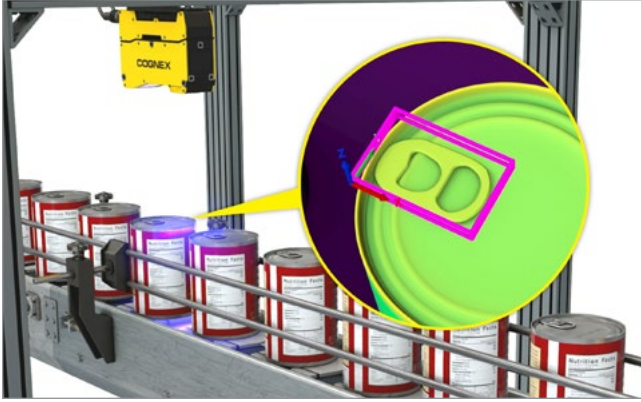

Check for dents, missing tabs, lifted tabs, and other defects to reduce scrap.

Cereal Bar Inspection

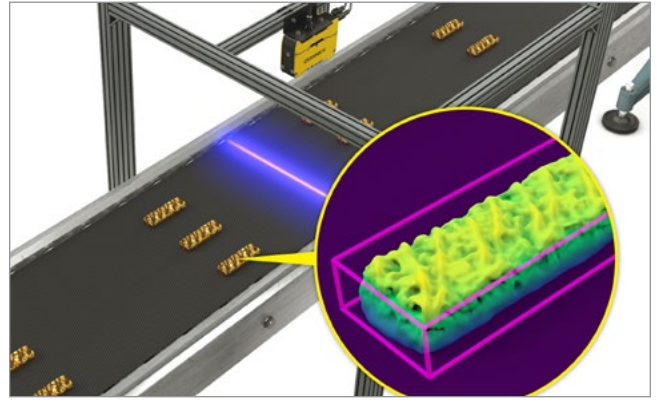

Ensure proper volume, detect defects, verify frosting/decoration location, and validate flatness.

Food Uniformity Inspection

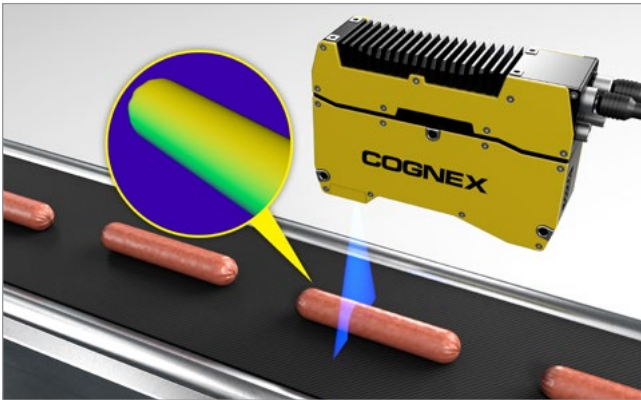

Measure height, length and width and calculate volume to detect minor variations in food uniformity.

Food Portioning Inspection

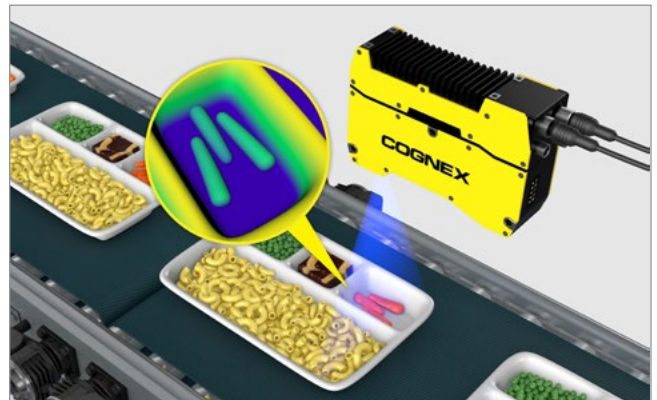

Measure portions in kitted meals.

Injection Molded Cup Inspection

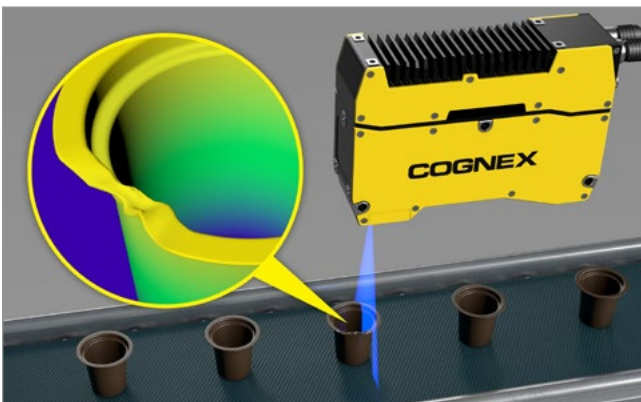

Inspect injection molded cups and verify proper dimensioning.

CONSUMER PRODUCTS

3D Machine Vision Solutions Deliver Product Quality, Safety, and Integrity

The consumer product and packaged goods industry demands high throughput, cost efficiency, and accuracy for its material handling, inspection, labeling, and assembly needs. Cognex is uniquely positioned to deliver the highest level of performance in product safety, product quality, and productivity improvements for consumer packaged goods (CPG) manufacturers. Cognex provides 3D machine vision solutions for every application, helping manufacturers maximize gross margin and customer satisfaction by improving product quality.

Cap Inspection

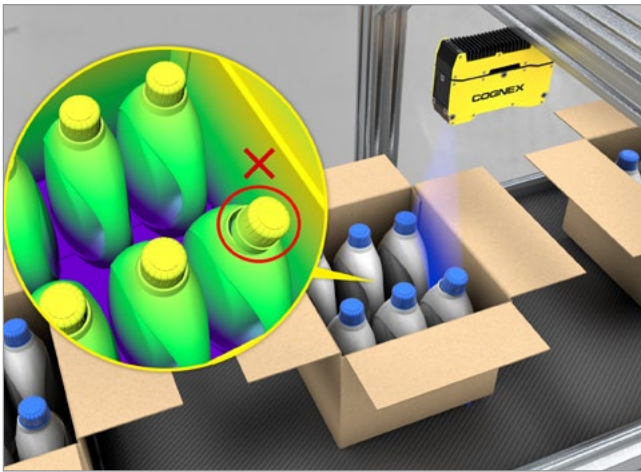

Verify the presence and position of the cap by checking the height and tilt.

Fill Level Inspection

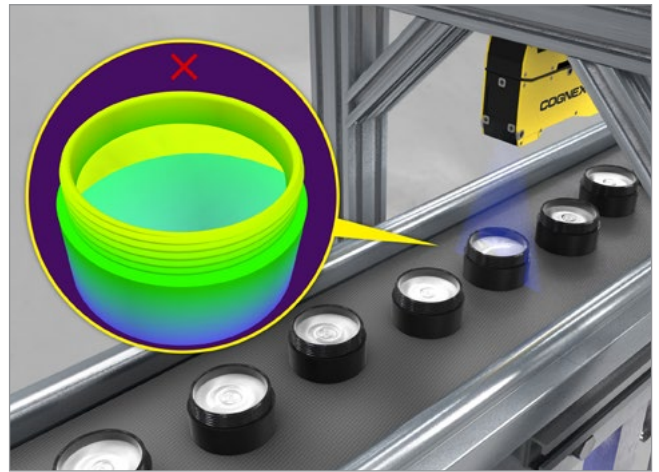

Inspect the height and volume of the contents to ensure the correct amount of product is in each container.

Packaging Quality Inspection

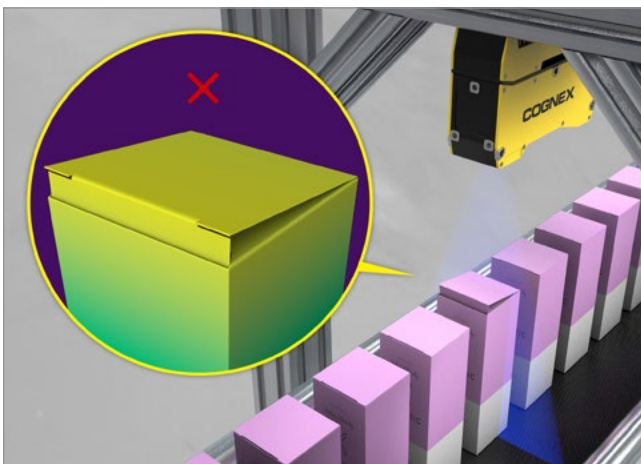

Verify the box is intact and sealed while inspecting for potential quality issues such as crushed corners, tears, or open flaps.

Flooring Inspection

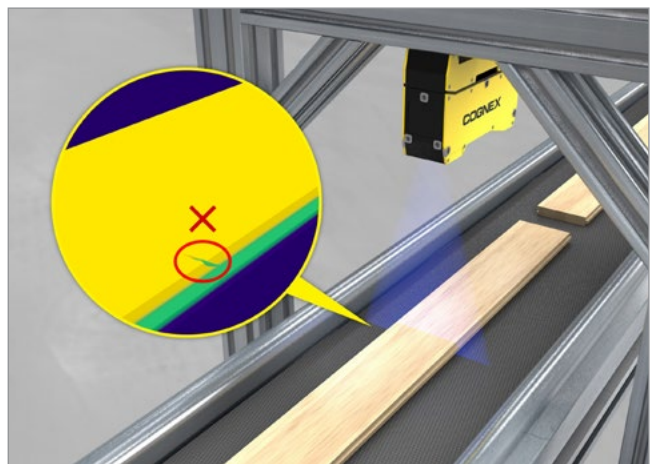

Inspect floorboards for orientation using the tongue. Check for surface defects including gouges, bowing, splits, and knotholes.

Shoe Detection and Inspection

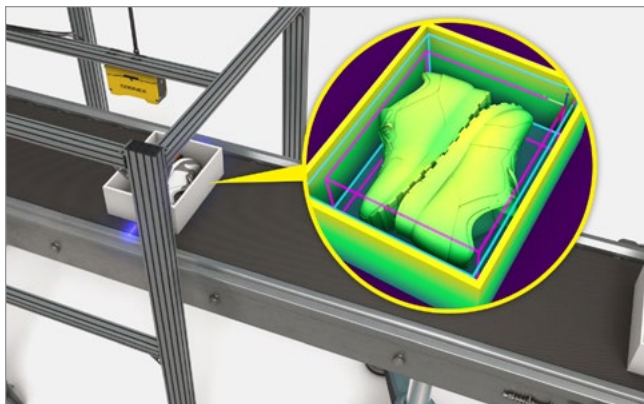

Ensure proper pairing, quality, aesthetics, and object presence/absence.

Soap Bar Inspection

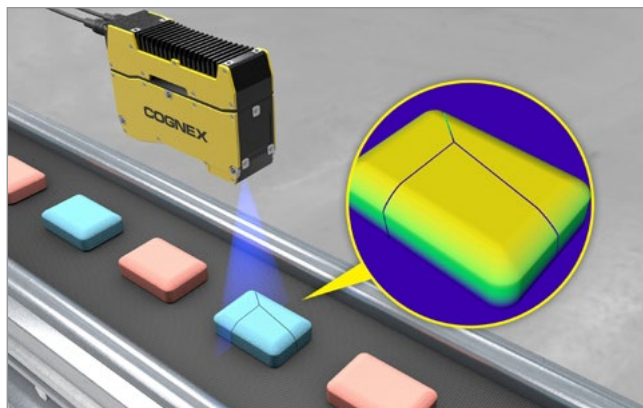

Inspect bar for damage and confirm dimensions prior to packaging process.

Tamper and Safety Seal Inspection

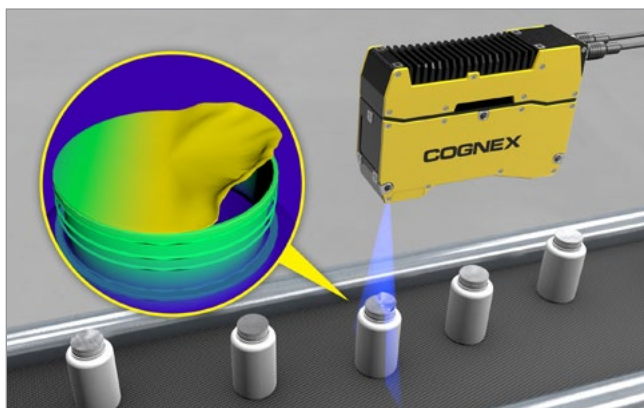

Verify seal integrity to avoid potential recalls and instill customer confidence.

Angled Sheet Metal Inspection



Measure curvature and edges of angled sheet metal to ensure proper dimensioning.

Rivet Inspection

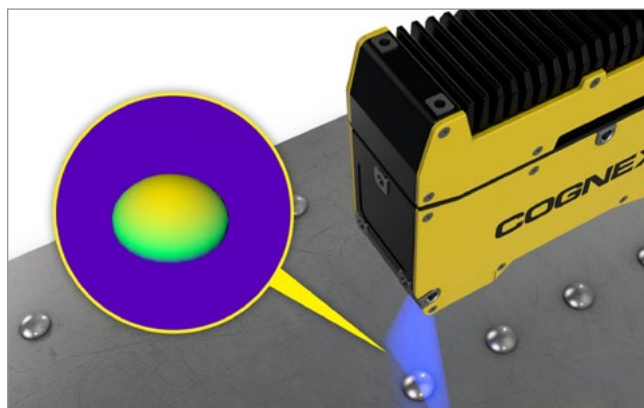

Confirm height of rivets and detect defects prior to sending sheet metal to the next stage of manufacturing.

LOGISTICS

Power Up Your Operations with 3D Vision Systems

As retail distribution, e-commerce fulfillment, and parcel processing industries continue to grow, the pressure to meet customer demands and performance metrics is greater than ever. Successful companies are scaling and optimizing operations while minimizing manual work and equipment downtime. Cognex 3D machine vision solutions deliver high accuracy and robust performance which helps improve traceability, increase throughput, and reduce costs associated with manual rework. In addition, these solutions provide rich real-time performance data and trending insights that help optimize operations.

Inbound Product Categorization

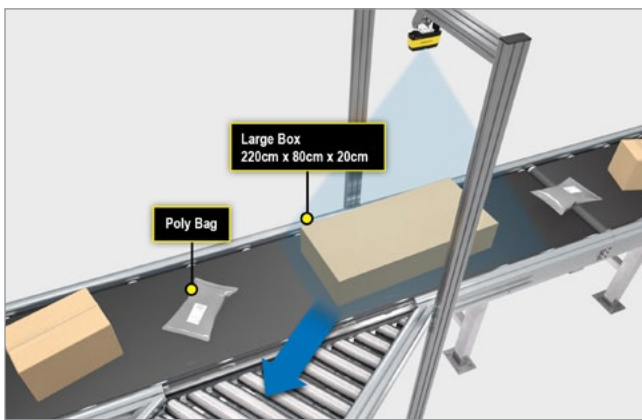

Capture dimensional information, categorize incoming freight, and provide item data for proper storage.

Manifest Verification

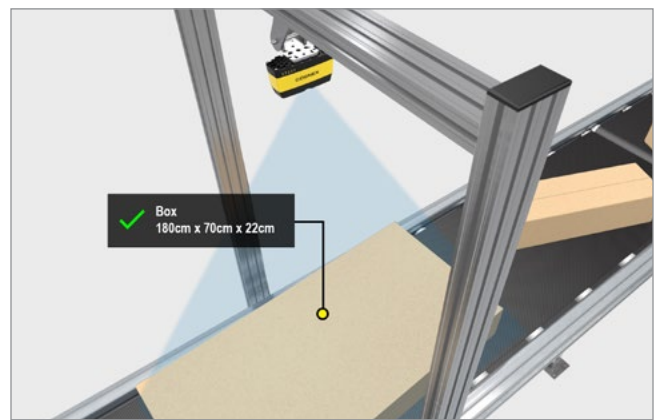

Capture volumetric and dimensional information of incoming products, improving traceability and verifying what was on the manifest.

Packaging Optimization

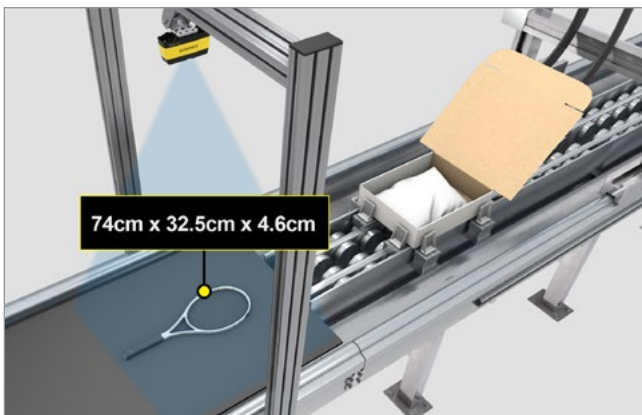

Automate volumetric measurement of picked products, reducing manual handling and measurement time, and lowering overall shipping costs.

Item Verification

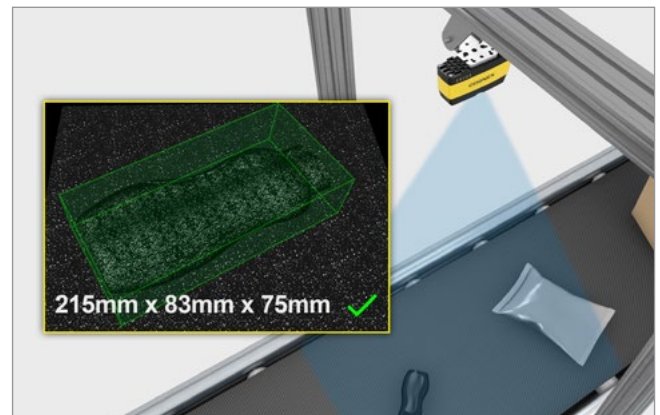

Capture volume and dimensioning data of picked items, increasing order accuracy, improving inventory management, and reducing return costs.

Categorizing Packages Prior to Shipment

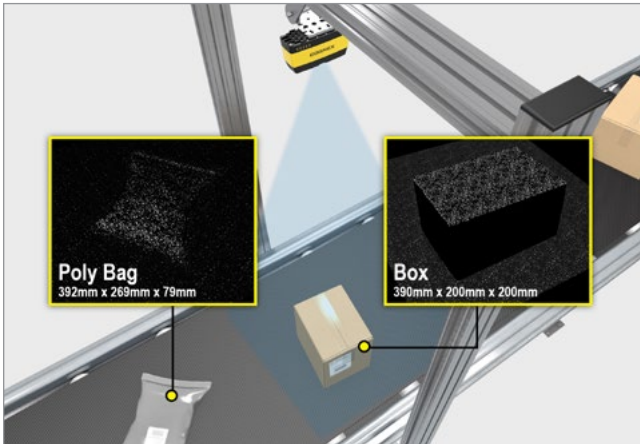

Categorize products to ensure proper handling and reduce damage to packages.

Item Detection

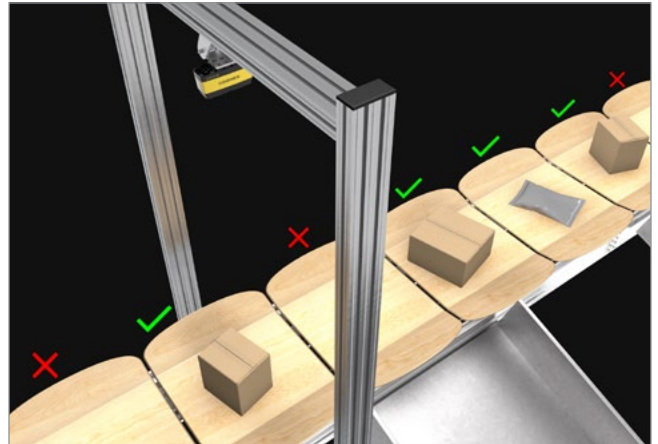

Identify products among dirt, dust, and foreign objects on the sorting belt, and monitor error codes to keep sorting systems running efficiently.

Estimating Shipping Costs



Capture and report dimensional and volumetric information, allowing operators to select the optimal packaging and more accurately estimate shipping costs.

Truck Load Optimization

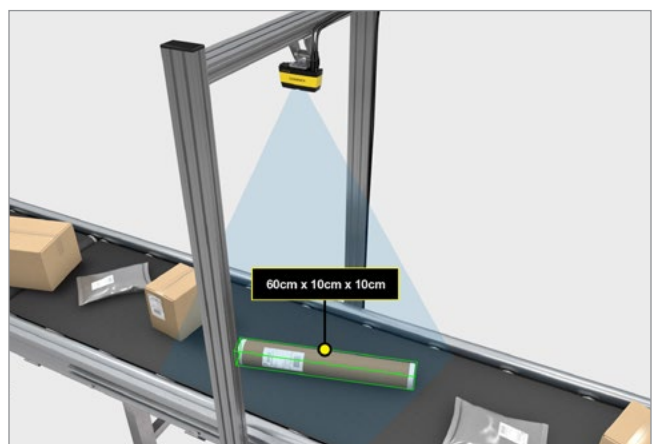

Collect dimensional and volumetric information for outgoing freight, enabling outbound handlers to pack their trucks efficiently to optimize transportation costs.

Customer Success

Industry-leading support that works the way *you* want, from self-service resources to a global network of experts



Plan & Deploy



Run & Support



Expand & Optimize

From initial planning to full-scale implementation, Cognex makes using advanced machine vision easy.

During planning and deployment, you'll get curated guidance on product choices and setup, single-click registration, and image-based AI training to get going quickly.

Once you're validated and in production, we keep you at peak performance with connected support and self-service training to take you from beginner to expert.

And over time, we help you scale up through a broad portfolio of products with shared interfaces and capabilities, as well as easy access to data that helps you grow and optimize across multiple facilities.



cognex.com/customer-success



Advanced machine vision made easy



The world's leading provider of vision systems, sensors, and software for automation

Cognex brings the power of vision to factory and warehouse automation of all kinds: detecting defects, monitoring production lines, guiding assembly robots, and tracking, sorting, and identifying parts. Our innovative technologies and focus on support throughout the customer journey make vision-based projects easier to set up, more effective, and more reliable.

Cognex machine vision solutions improve product quality and reduce costs at leading manufacturers and logistics providers worldwide, and our mature AI technology makes them more capable and easier to install, maintain, and operate.

Advancing automation is complicated enough already. We make it easier by providing industry-leading support that works the way customers want, from self-service resources to a global network of experts.

>40 years in business

25K+ global customers

500+ global customer support resources

>1,100 technology patents

Build Your Vision

Vision Systems

Advanced AI makes it easy to deploy vision systems for automating inspection tasks, from defect detection to assembly verification and text reading.

www.cognex.com/machine-vision



Barcode Readers

Track and trace from the floor to dock door, with flexible readers and verifiers designed for ease of use and reliability.

www.cognex.com/barcodereaders



Industry Solutions

Tackle complex applications across a wide range of industries with powerful machine vision solutions that simplify today's manufacturing and logistics challenges.

www.cognex.com/solutions



COGNEX

Companies around the world rely on Cognex vision and barcode reading solutions to optimize quality, drive down costs, and control traceability.

Corporate Headquarters
One Vision Drive
Natick, MA 01760 USA

Contact us or find your regional sales office:
www.cognex.com/sales

Americas

North America +1 855 426 4639
Brazil +1 855 426 4639
Mexico +52 552 789 5444

Europe

Austria +49 721 958 8052
Belgium (FR) +33 176 549 318
France +33 176 549 318
Germany +49 721 958 8052
Ireland +353 21 601 9005
Italy +39 02 9475 4345
Spain +34 93 220 6237
Switzerland (DE) +49 721 958 8052
Switzerland (FR) +33 176 549 318
United Kingdom +353 21 601 9005
Other Europe +353 21 601 9005

Asia-Pacific

China +86 218 036 5424
India +91 7305 040397
Japan +81 345 790 266
Korea +82 704 784 4038
Singapore +65 3158 2511
Taiwan +886 801 492 017
Other Asia-Pacific +65 3158 2511

© Copyright 2025, Cognex Corporation.
All information in this document is subject to change without notice. All Rights Reserved. Cognex and In-Sight are registered trademarks of Cognex Corporation. DSMax is a trademark of Cognex Corporation. All other trademarks are property of their respective owners. Lit. No. 3DMVSG-02-2025

www.cognex.com